



## Neo Shower Enclosure Fitting Instructions

### IMPORTANT

Please read carefully the following instructions before installing your shower enclosure. If you have any questions on this shower enclosure installation - please call our technical support specialists Monday to Friday 9:00AM – 6:00PM EST at **1-866-731-8378 Option 3** or e-mail our technical support group at [support@BathAuthority.com](mailto:support@BathAuthority.com)

### Preparation

1. After opening the case, read this introduction carefully, check all the packed parts are complete by cross checking all the components against the “Diagram of Shower Enclosure Components”. Examine for shipping damage. If the unit has been damaged or has a finishing defect, please contact your local distributor within 2 business days. Please note that **Bath Authority™ / DreamLine™ will not replace any damaged product or parts free of charge, ONCE the product has been installed.** Your distributor’s responsibility for damage in transit is limited after the shower package has been transferred to the transportation company, so you may have to contact the transportation company directly to report damage. Contact your distributor or DreamLine if you have any questions.
2. You should make sure that the floor is leveled and solid and will be able to support the total weight of the unit and its occupant. You should also consult your local building codes on questions on installation compliance standards.
3. Install all of the required plumbing and drainage before securing the shower. **Use a competent and licensed (if required by local code) plumber for all plumbing installation.**
4. Please insure that prior to the installation the floor is leveled and the walls are at right angles. While some adjustment in leveling of the tray is possible, irregular floor level or improper angle of side walls will result in serious problems for your installation. Please, note that there are some adjustments and drilling might be necessary during the installation process.

### Tools Required

Electric drill, Masonry drill bit (D=6mm not provided), Pencil, Phillips screwdriver, Slotted screwdriver, Tape measure, Spirit level with horizontal and vertical indicators.

Note: If glass has silk, print or molded designs, please put clear side toward inside.

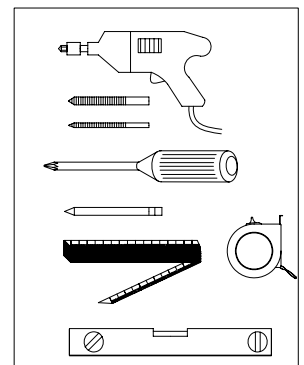

## Detailed Diagram of Enclosure Components

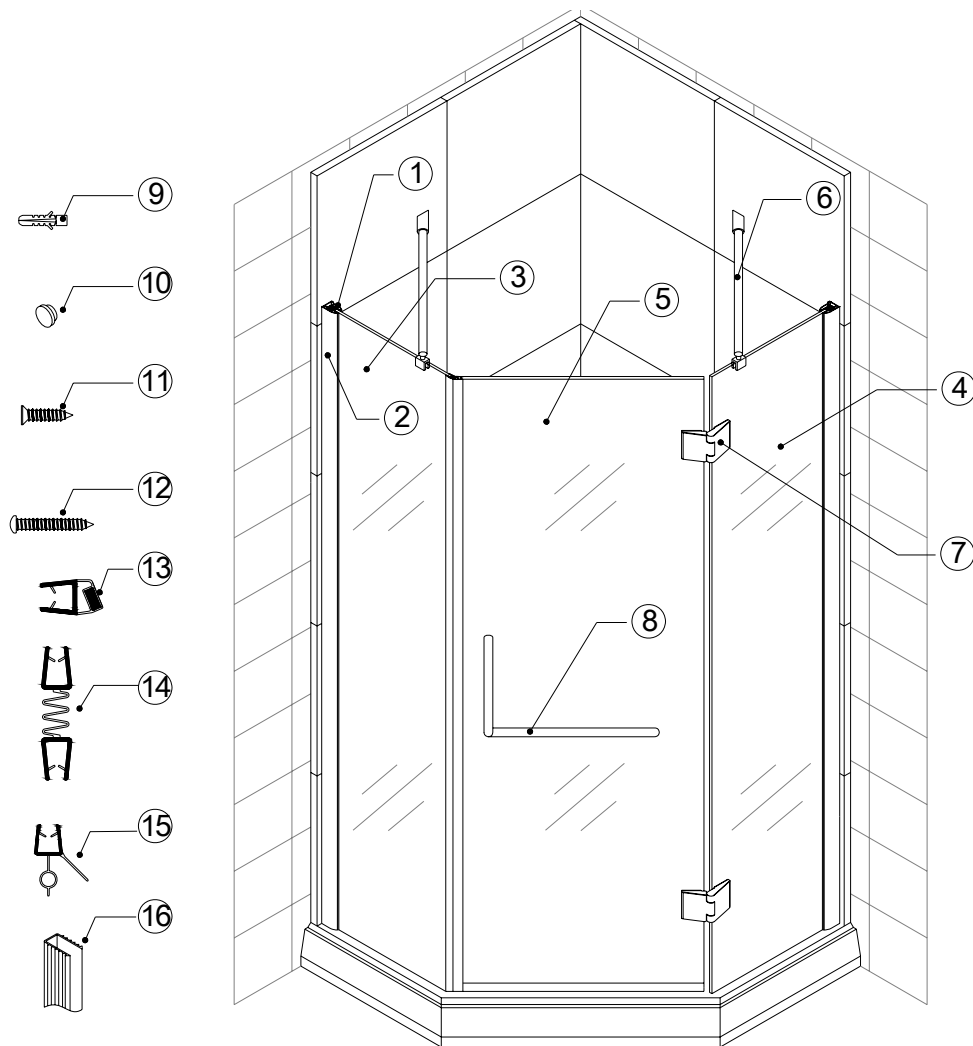

### Packing List

01	Glass profile	2pcs	09	Wall anchors	10pcs
02	Wall profile	2pcs	10	Screw cover	8pcs
03	Stationary glass 1	1pcs	11	Screw ST4.2×15	8pcs
04	Stationary glass 2	1pcs	12	Screw ST4.2×30	10pcs
05	Glass door	1pcs	13	Magnetic strip	2pcs
06	Bracket assemble	2pcs	14	Connected anti-water strip	1pcs
07	Hinge	2pcs	15	Bottom anti-water strip	1pcs
08	Handle	1set	16	“U”shape seal gasket	2pcs

**Now you have checked that all components are there, you are now ready to start the installation of your Dreamline shower enclosure.**

### **Assemble steps**

1. Install a shower tray according the Tray installation manual. You should do it before the wonder board and finish wall installation.  
The shower enclosure has to be installed after you finish the wall.
2. You can start installation from any side of the wall. Locate the **wall profile (2)** from the package, then place it vertically above the tray 35  $\frac{3}{4}$ " or 38  $\frac{1}{4}$ " (depending on size of your enclosure) from the corner to the external edge of the profile. Using a level adjust the wall profile upright, then use predrilled into aluminum profile holes to put on marks for drilling. Now drill the holes and insert the **wall anchors (9)** into the hole. Use ST4.2x30 screws round head self-tapping screw (12) to attach the wall profile to wall (fig 1).  
**Be sure that profile is absolutely vertical.**
3. Attach the second part of **glass profile (1)** to the **wall profile** using ST4.2x15 round self-tapping screw (11) slightly fasten the profile (fig 2).
4. Have out the **stationary glass panel (3)**. Place a **u-shape gasket(16)** on the long (vertical) side of the glass panel; then fit the glass with the gasket into the assembled **wall Profile (1)**, then fasten it tight (fig 2).
5. Repeat step 1-3 to install second **wall profile** and the **stationary glass panel (4)**. Check, if stationary glass installed vertical in both directions.
6. Place the **bracket assemble** over the stationary glass (fig 3). Assemble should be paralleled to the floor and the wall mounting bracket of assemble has been flat with the wall. Mark the hole on the wall through the mounting bracket. Drill holes on the wall at this mark, insert anchor and secure bracket assembles to the wall. Complete the assembly by inserting of plastic gaskets between brackets and glass and tightening the screws. Do not fasten it very tight as you may need to adjust it.
7. Install the **hinges (7)** onto the narrow stationary glass panel and the glass door. Upper edge of **Glass door** should be on the same level as upper edge of the **stationary glass**. You will need assistance in this process. Start off by attaching the hinges to the stationary glass panel. Place the hinge from the outside and screw it in from the inside, do this for the bottom hinge and the top hinge, but start first from the top hinge when you begin to put the door on. Make sure that until both hinges are installed securely, the door does not swing around or lean/bend to any side because that could cause the hinge to snap. After the hinges are installed open and close the door to make sure it's nice and smooth (fig 4). Push on the **connected anti-water strip (15)** to seal between glass door and narrow stationary glass (fig 5).
8. Install the **handle** to the **glass door**. Locate the Vertical Handle and Horizontal Handle (9). The horizontal handle will be on the outside and the vertical handle will be on the inside of the door. Start the installation from the outside which will involve the horizontal handle first. Don't forget to use the rubber gaskets between the glass and washers.
9. Install **magnetic strips (13)** and **bottom anti-water strip (15)** on the door (fig 5).

10. Apply silicone sealant along the wall profiles and bottom guide rail (fig 7).

**NOTE: You can have right or left opening of the door depending where you install stationary glass (4).**

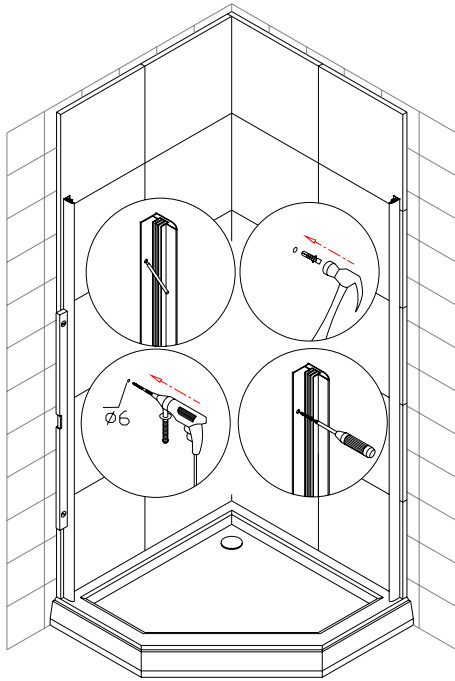

Fig 1

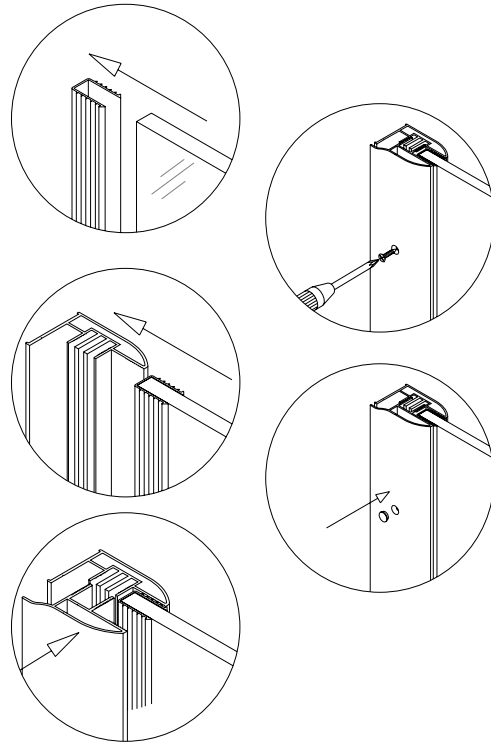

Fig 2

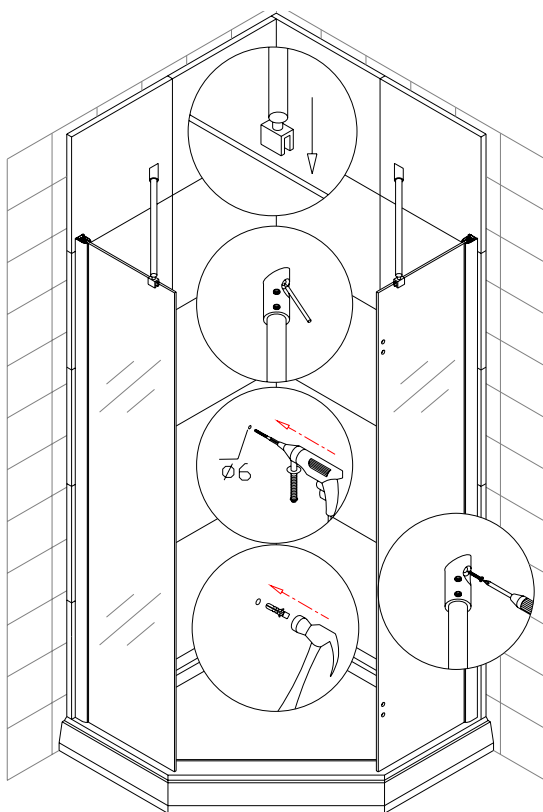

Fig 3

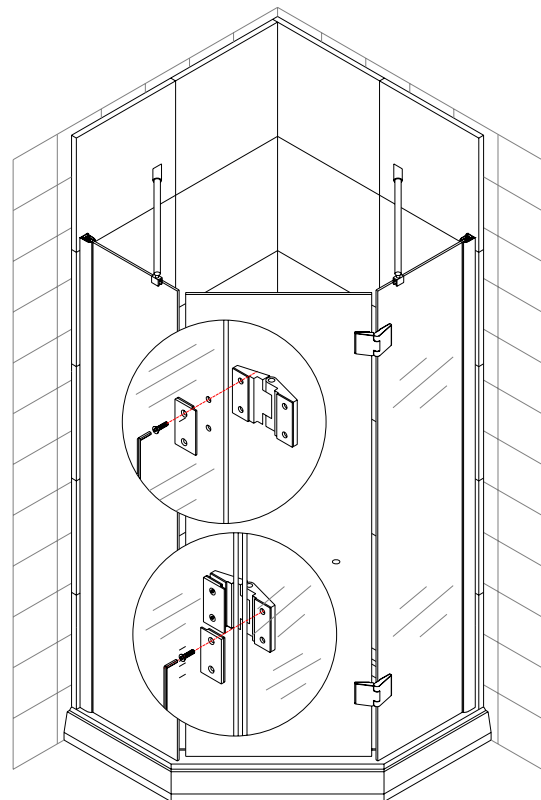

Fig 4

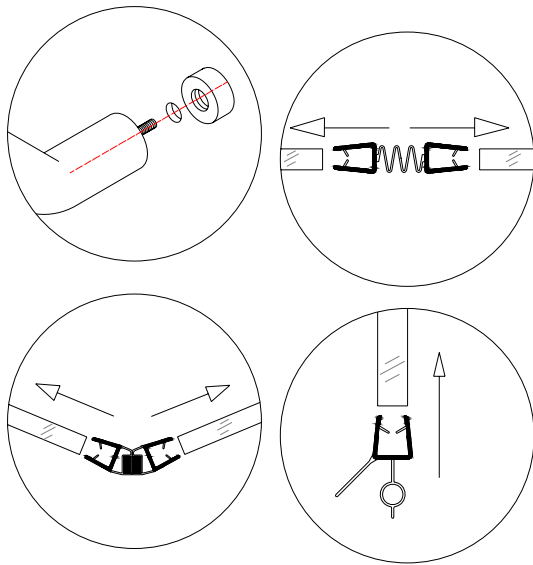
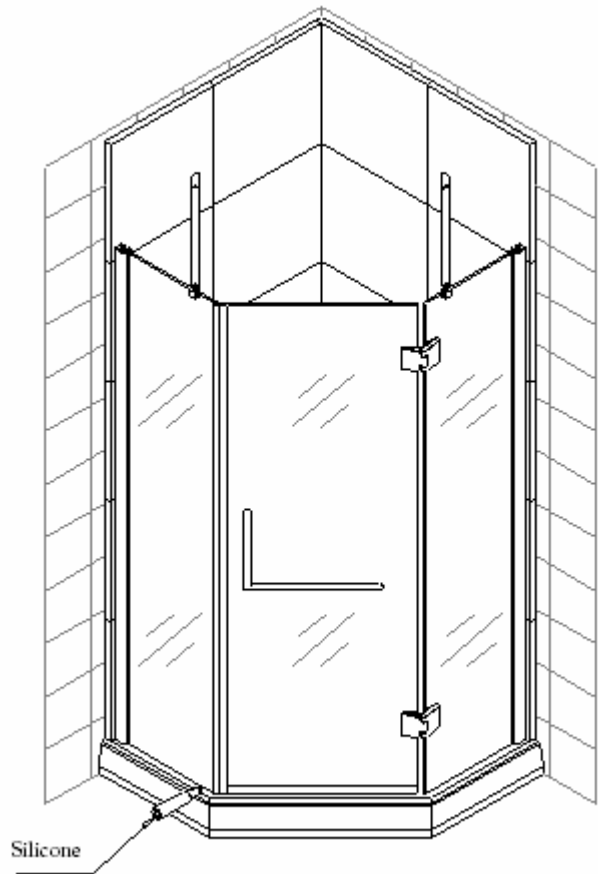

Fig 6

Fig

5



## **Product Maintenance**

1. Tempered glass can be clean with nonabrasive bathroom cleaner or any glass cleaner you use elsewhere in your home. Rinse off any glass cleaner that gets on the aluminum as soon as possible to avoid damage to the anodized surface. Avoid striking it with any sharp or hard objects. Such damage can cause either immediate or delayed breakage of tempered glass.
2. The aluminum in your shower door is durable and resistant to water damage. It is advisable, but not necessary to wipe it with your towel after your shower. Clean it as often as needed to keep the buildup off. Never use any type of abrasive cleaner. Use only a soft damp cloth and nonabrasive bathroom cleaners.

**Our product may have changes without prior notice**

**Bath Authority™ LLC / DreamLine™  
Shower Enclosure, Jetted/Steam Shower and Shower Columns  
Limited Warranty**

## CONSUMER RESPONSIBILITIES

Your DreamLine™ Shower Products will remain beautiful for many years if you take care of them. Some of the waterproofing plastic strips and other seals will need to be replaced when they show signs of wear, yellowing, or are not watertight. Refer to the parts list of your manual for all seals. Water conditions in various parts of the country will determine any extra cleaning attention you may have to give your new shower enclosure or jetted shower. DreamLine™ does not recommend the use of harsh abrasive cleansers on any of its products. Harsh cleansers will damage the metal or glass finish on your shower enclosure or jetted shower.

## REQUESTING SERVICE

Here's what you need to do if you require service:

1. Contact the dealer who sold and/or installed the product. They should be able to solve any problems you may have.
2. If your dealer or contractor cannot solve the problem, they will contact or supply you with the name of the local DreamLine™ Distributor or a DreamLine™ Direct Technical Specialist
3. If you are unable to obtain warranty service through either your contractor or DreamLine™ distributor, please write us directly at

Bath Authority™ LLC / DreamLine™  
909 Louis Drive  
Warminster, PA 18974  
ATTN: Customer Service Department

4. Include all pertinent information regarding your claim, including a complete description of the product, model numbers, colors, finishes, and the date the product was installed. Include a description of the problem and a photocopy of your invoice and purchase receipt(s) for the products involved. Also please provide information on the name and contact telephone numbers of the contractor and distributor.

Please note that under any circumstances, DreamLine™ products should not be returned to your dealer, distributor or directly to DreamLine™ without a written Return Merchandise Authorization (RMA).

## LIMITED ONE-YEAR WARRANTY

This warrantee extends only to the original owner/end-user for personal household use only. For commercial uses, additional limitations may apply.

DreamLine™ warrants acrylic surface against blistering or cracking and chipping resulting from defect in the acrylic surface material when used under normal condition and service for a period of one (1) year from the purchase date.

DreamLine™ warrants mirrors, shower doors, shower massage systems, faucet finishes and fittings to be free from defects in workmanship and materials under normal use and service for a period of one (1) year.

DreamLine™ further warrants the structure of the acrylic shell against loss of water through the fiberglass laminate of the acrylic body as a result of defect in materials and workmanship for a period of five (5) years from the purchase date.

DreamLine™ will, at its election, repair, replace, or make appropriate credit adjustment where DreamLine™ optional inspection discloses any such defects occurring in normal usage within the warrantee periods. **Please note that DreamLine™ is not responsible for any installation or removal costs.**

Improper modification of any enclosure, jetted shower or shower column components may void the warrantee - so please install the product as directed in the manual. This warrantee does not cover any claim arising from abuse, misuse, negligence, accident, improper installation or operations on the part of the purchaser. This warrantee is void if the DreamLine™ product is subject to alterations, or if repairs are attempted by anyone other than an authorized agent of DreamLine™. This warrantee does not extend to any plumbing or components installed by dealers, installers or by any party other than DreamLine™.

**Implied warranties, including that of merchantability or fitness for a particular purpose, are expressly limited in duration to the duration of this warranty. DreamLine™ disclaims any liability for special, incidental, or consequential damages.**

Some states do not allow limitations on how long an implied warranty lasts or the exclusion or limitation of special, incidental, or consequential damages, so these limitations and exclusions may not apply to you. This warranty gives you specific legal rights. You may also have other rights which vary from state to state. This limited warranty provides specific legal rights as they apply within the USA, and other rights may be available, but may vary from country to country.

***This is our exclusive written warranty for DreamLine™ Shower Enclosure, Jetted/Steam Shower and Shower Column purchases made after May 2004. DreamLine™ reserves the right to modify this warranty at any time, and the consumer understands that such modification will not alter the warranty conditions applicable at the time of the sale of the product.***