

## Technical Charts | Washers and Combination washer-dryers

Model	AW 149 NA	AW 129 NA	AW 125 NA	AWD 129 NA	AWD 121 NA
<b>Product Line</b>	washing machine	washing machine	washing machine	combo washer/dryer	combo washer/dryer
<b>Color</b>	platinum	platinum	platinum	platinum	white
<b>Performances</b>					
Energy test washing capacity	15 lbs / 7.0 kgs	15 lbs / 7.0 kgs	12 lbs / 5.5 kgs	12 lbs / 5.5 kgs	12 lbs / 5.5 kgs
Energy test drying capacity				8 lbs / 3.6 kgs	8 lbs / 3.6 kgs
Maximum washing load	16 lbs / 7.5 kgs	16 lbs / 7.5 kgs	13 lbs / 6.0 kgs	13 lbs / 6.0 kgs	13 lbs / 6.0 kgs
Energyguide	189 kWh/year	189 kWh/year	176 kWh/year	176 kWh/year	176 kWh/year
Heating Element	1000 W	1000 W		1300 W	1300 W
Approval	UL / CUL	UL / CUL	UL / CUL	UL / CUL	UL / CUL
<b>Primary Functions</b>					
Sanitary Wash	■	■	■	■	■
Cotton Wash	Heavy, Regular, Light	Heavy, Regular, Light	Heavy, Regular, Light	Heavy, Regular, Light	Heavy, Regular, Light
Permanent Press Wash	Heavy, Regular, Light	Heavy, Regular, Light	Heavy, Regular, Light	Heavy, Regular, Light	Heavy, Regular, Light
Delicates Wash	Delicates, Silk, Wool	Delicates, Silk, Wool	Delicates, Silk, Wool	Delicates, Silk, Wool	Delicates, Silk, Wool
Daily Wash	■	■	■	■	■
Variable temperature	■	■	■	■	■
Variable drying time	■	■	■	■	■
Variable spin speed	Up to 1400 rpm	Up to 1200 rpm	Up to 1200 rpm	Up to 1200 rpm	Up to 1200 rpm
<b>Additional Options</b>					
Super Wash	■	■	■	■	■
Pre-Wash	■	■	■	■	■
Easy Iron	■	■	■	■	■
Delay Timer	■	■	■	■	■
Extra Rinse	■	■	■	■	■
Soaking	■	■	■	■	■
Bleach Stain Removal Program	■	■	■	■	■
<b>Dimensions</b>					
Product only (HxWxD)	850mm x 595mm x 580mm 33.47" x 23.43" x 22.84"	850mm x 595mm x 580mm 33.47" x 23.43" x 22.84"	850mm x 595mm x 535mm 33.47" x 23.43" x 21.07"	850mm x 595mm x 535mm 33.47" x 23.43" x 21.07"	850mm x 595mm x 535mm 33.47" x 23.43" x 21.07"
Product with packaging (HxWxD)	910mm x 635mm x 615mm 35.83" x 25.00" x 24.22"	910mm x 635mm x 615mm 35.83" x 25.00" x 24.22"	910mm x 635mm x 595mm 35.83" x 25.00" x 23.43"	910mm x 635mm x 595mm 35.83" x 25.00" x 23.43"	910mm x 635mm x 595mm 35.83" x 25.00" x 23.43"
Door opening	13"	13"	13"	13"	13"
<b>Weight</b>					
Product only	158.7 lbs / 72.0 kg	158.7 lbs / 72.0 kg	145.5 lbs / 66.0 kg	137.3 lbs / 62.3 kg	137.3 lbs / 62.3 kg
Product with packaging	162.1 lbs / 73.5 kg	162.1 lbs / 73.5 kg	149.7 lbs / 67.9 kg	141.5 lbs / 64.2 kg	141.5 lbs / 64.2 kg
<b>Technical Data</b>					
Voltage / Frequency	120 volts / 60 hz	120 volts / 60 hz	120 volts / 60 hz	120 volts / 60 hz	120 volts / 60 hz
Amperage / Wire	11 Amps / 3 prong plug	11 Amps / 3 prong plug	11 Amps / 3 prong plug	13 Amps / 3 prong plug	13 Amps / 3 prong plug
Cable length	6 ft. / 1.8 mts	6 ft. / 1.8 mts	6 ft. / 1.8 mts	6 ft. / 1.8 mts	6 ft. / 1.8 mts
Motor	Triphase (quiet)	Triphase (quiet)	Triphase (quiet)	Collector	Collector
Detergent recovery system	■	■	■	■	■
Antifoam protection	■	■	■	■	■
Overflow / Flood protection	■	■	■	■	■
Tub & Drum	Poliplex / Stainless Steel	Poliplex / Stainless Steel	Stainless Steel	Stainless Steel	Stainless Steel
Adjustable feet	4	4	4	4	4
Suspension System	2 springs / 2 dampers	2 springs / 2 dampers	2 springs / 2 dampers	2 springs / 2 dampers	2 springs / 2 dampers
<b>Warranty</b>					
2 years Parts & Labor (*)	■	■	■	■	■
5 years Electronic components (Parts only) (*)	■	■	■	■	■
Lifetime against rust (*)	■	■	■	■	■
<b>Accessories</b>					
Instruction Manual	English, Spanish, French	English, Spanish, French	English, Spanish, French	English, Spanish, French	English, Spanish, French
Warranty card	included	included	included	included	included
Connection hoses	included	included	included	included	included
Pedestal with drawer (APE 2000 S)	sold separately	sold separately	sold separately	sold separately	sold separately
Pedestal without drawer (APE 1000 S)	sold separately	sold separately	sold separately	sold separately	sold separately

(\*) Certain limitation apply, see manufacturers limited warranty for details  
Ariston reserves the right to bring changes to the products without notice.  
UL and CUL listed

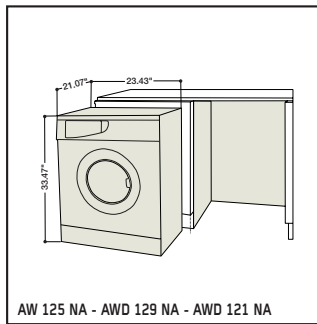
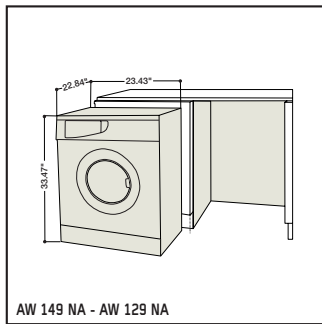

For planning purposes only,  
for details see care & use manual  
Staked installation Height 67"

Warranty: 2 years parts & labor, 5 years on all the  
electronic components (parts only), lifetime  
warranty against rust - through on stainless steel  
tub (certain limitations apply, see manufacturers  
limited warranty for details).